



MWE 209 FI Built-In Microwave + Grill Of 20 Litres



20L capacity



Defrost by time



Defrost by weight



Direct access menu

DESCRIPTION

Built-In Microwave + Grill Of 20 Litres

LIFE STYLE

Easy

COLORS



REFERENCE

REF. 40581101
EAN. 8421152127186



MWE 209 FI

FEATURES

Capacity: 20 litres
8 Direct Access Menu
Defrosting by weight and time
Children Safety Block Option



MWE 209 FI

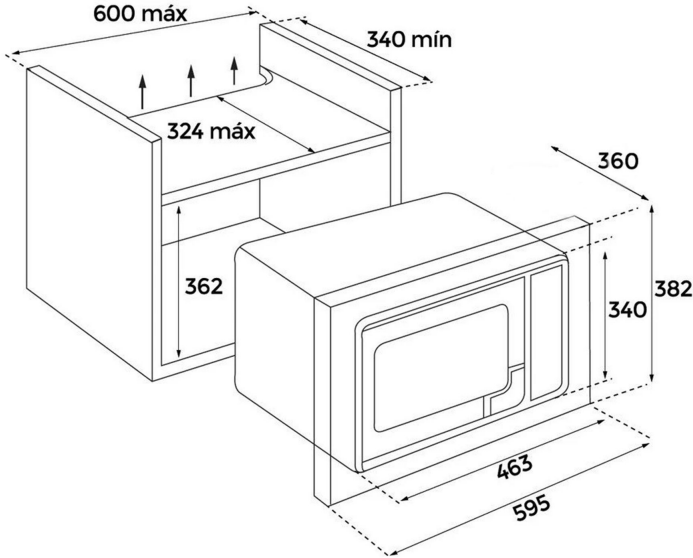

DIMENSIONS

- Product height (mm): 340
- Product width (mm): 463
- Product depth (mm): 359
- Product length (mm):
- Net weight (Kg): 15,0

TECH SPECS

FEATURES

- Certificates: GS / EMC
- Number of cooking functions: 3
- Grill function: Yes
- Minute Minder: Yes
- Number of guide levels (lower cavity): 0
- Microwave function: Yes
- Microwave + Grill function: Yes
- Number of power levels: 5

ELECTRIC CONNECTION

- Maximum Nominal Power (W): 1250
- Frequency (Hz): 50
- Power rate (V): 230
- Inside light Consumption (W): 20

ENERGY CONSUMPTION

- Grill (W): 1000
- Turbo (W): 0

SAFETY SYSTEMS

Children safety block option: Yes

Safety Thermostat: Yes

ACCESSORIES

Glass Tray: 1

Crunch plate: 0

